

Submersible Drainage Pump Type ABS J 5

Specification

Electric submersible pump.
 Maximum submergence: 8 m. • Protection class IP 68.
 pH of the pumped medium 5-8 • Strainer hole 6 mm.

J 5 W Medium head, single-phase.

Electric Motor

Single-phase induction motor with built-in capacitor, 50Hz.
 Class B insulation
 Motor rating P_2 : 0.48 kW. Speed: 2690 rpm

Voltage, V	230
Nominal current, A	2.9

Power Cable

10 m type HO7RN-F: 3 x 1.0 sq.mm.

Motor Protection

Built-in thermal protector.

Shaft Seal

Double mechanical seal in oil bath with oil circulator.
 Primary seal: Silicon carbide on silicon carbide.
 Secondary seal: Carbon on ceramics.

Bearings

Shielded ball bearing.

Discharge Connections

2" hose connections.
 2" B.S.P. threaded connections.

Weight (without cable)

9.5 kg

Options and Accessories

Automatic level control unit
 Discharge connection accessories and hose

EN 50 Hz

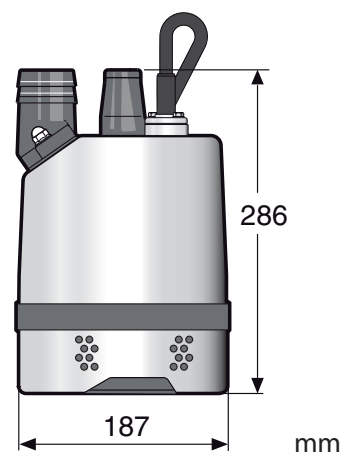
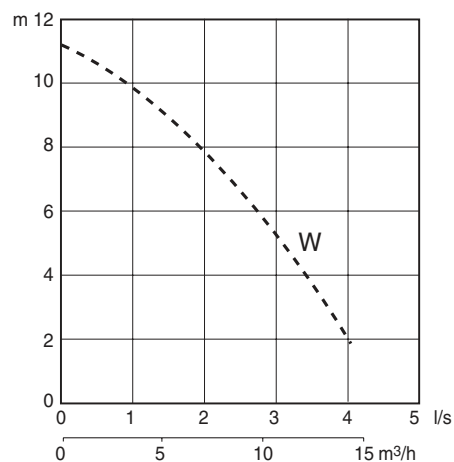

Materials

Castings	Aluminium
Casing	Stainless steel
Shaft	Stainless steel
Impeller	Polyurethane
Wear parts	Ethylene propylene rubber/ Polyurethane
O-rings	Nitrile rubber